

e-ASK

electronic **A**ccess **S**ecurity **K**eyless-entry

Discrete e-PAD **Instruction Manual** (UM10 ~ 21067-01)



500 Bailey Avenue
P.O. Box 350
New Hampton, Iowa 50659 U.S.A.
Tel: 641-394-3188
Fax: 641-394-2392
www.trimarkcorp.com

Table of Contents

Introduction	1
e-PAD Operation and Features	1
Locking Doors With Keypad	2
Secure Operations	2
Dome Light Activation	2
Protective Deactivating Security Feature	2
Buzzer Operation	3
Keypad Backlight Operation	3
Teaching Keypad New Authority / Access Codes	3
Changing Authority Code	3
Change / Add Access Codes	4
Appendix A: Mounting Information	I
Appendix B: Wiring Information	II
Wire Identification	II
Wiring Diagram	III

Introduction

This manual provides the necessary information for the proper installation and use of TriMark's discrete **e-PAD** system.

Note: Some features discussed in this manual may not be available on your system.

e-PAD keypad



Note: Horizontal or vertical **e-PADs** are available.

e-PAD Operation and Features

The **e-PAD** is shipped with default authority and access codes. Unless the OEM or dealer has changed the default codes, the authority and access codes are as follows:

Access code:

Digit 1	Digit 2	Digit 3	Digit 4	Digit 5
1 / 2	3 / 4	5 / 6	7 / 8	9 / 0

Authority code:

Digit 1	Digit 2	Digit 3	Digit 4	Digit 5
7 / 8	7 / 8	7 / 8	7 / 8	7 / 8

Locking Doors With Keypad

Press and hold down the (1 / 2) button for 1-2 seconds. An access code is not needed to lock the doors.

Secure Operations

Entering a valid 5-digit access code enables secure operations. After entering an access code, the keypad is enabled for 5 seconds and a 6th button press initiates a secure operation, such as unlocking the doors.

The table below shows the default button assignments:

1 / 2 Button	Unlocks entry doors
3 / 4 Button	Unlocks cargo doors
5 / 6 Button	No function
7 / 8 Button	Unlocks entry and cargo doors with staggered actuation
9 / 0 Button	Activates light for 5 minutes. Repeating sequence while light is on turns light off.

Notes:

- The authority code does not allow for secure operations. It is only used to assign access codes (see page 3 for information on setting authority and access codes).
- If an unassigned button or no button is pressed while the system is enabled, the keypad reverts back to disabled state.
- The secure keypad operations are set depending on the system configuration.

Dome Light Activation

The dome light is activated for 30 seconds whenever a secured operation occurs.

Protective Deactivating Security Feature

After repeated entering of incorrect codes (20 button presses without enabling), the keypad is deactivated for 1 minute. This helps prevent unauthorized access by entering random codes.

No beep will sound with button press while the system is disabled.

Buzzer Operation

The buzzer chirps once when power is first applied to the keypad and for each key press during regular use. When an authorized access code is entered, the system chirps twice to indicate readiness for a secure operation (6th button press).

The system chirps twice for each button press while in Learn Mode. When a new access code is defined, the system chirps 3 times.

Keypad Backlight Operation

When the **e-PAD** is in the normal state, the backlighting is at a low level. When a button is pressed, the keypad backlight flashes bright.

The keypad backlight also has a power saving mode if voltage is below 11 volts, the continuous backlighting is shutoff until the battery is fully charged. When continuous backlighting is off, the keypad still “wakes up” when a button is pressed. In this case, the backlighting is activated for only one minute.

If the battery voltage is increased to 12.5V for 5 minutes, then the keypad back lighting will return to low brightness level.

Teaching Keypad New Authority / Access Codes

Change Authority Code

The following procedure resets the default authority and access codes. It then assigns a new authority code. The authority code is only used to teach access codes.

Notes:

- The memory for authority and access codes is NON-VOLATILE and will not be erased if power is removed.
- Changing the authority code is the only activity that requires access to the learn mode wire in the wiring harness.

The procedure is:

1. Ground the yellow wire. The buzzer will chirp for approximately 3 seconds and the keypad backlights will flash to indicate learn mode (back lights can only be seen when dark).
2. Enter the new 5-digit code. (Double chirps after each button press). The keypad will chirp 3 times after the 5-digit entry.
3. Enter the new code again for confirmation. (Again double chirps after each button press). Then keypad will chirp four times after the 5-digit code is confirmed. A long beep indicates that codes did not match (if this occurs then previous codes remain, keypad exits from learn mode, and above steps need to be repeated to change codes).
4. The keypad will automatically exit learn mode after successive completion of steps 1-3 above. Next confirm that the above code works as an access code. Now each button press will only provide 1 chirp, and then a double chirp indicates that the keypad is enabled (and ready for secured operation depending on 6th button press).

The user is given 2 minutes to complete this procedure. If it isn't completed in time, or an error is made, the system will exit learn mode and a long chirp will sound to indicate the error.

The following area can be used to document the authority code:

Authority Code				
Digit 1	Digit 2	Digit 3	Digit 4	Digit 5

Change/Add Access Codes

With a valid authority code, an access code can be programmed with the following instructions.

1. Press the (5 / 6) button for 5 seconds, the keypad will beep. The backlighting LED of the keypad will flash indicating the learn mode.
2. Enter in the 5-digit authority code. Keypad will provide a long beep that will stop after you have defined an access number.

3. Press and release the button that corresponds to the access number. For example, press the (1 / 2) button for access #1 and press the (3 / 4) button for access #2. The keypad will provide a confirmation beep after this single button press.
4. Enter the new 5 digit access code after this single button press.
5. Re-enter the new 5 digit access code. The keypad will provide confirmation beeps.

Repeat process to assign additional access codes.

Note: Up to 5 different access codes can be assigned at one time. As additional access codes are defined, pre-existing access codes are overwritten. For example, if a new access code is assigned for access #3, the previous access #3 code is no longer valid.

The following area can be used to document the access code assignments.

Access #	User Name	Digit 1	Digit 2	Digit 3	Digit 4	Digit 5
1						
2						
3						
4						
5						

This product has been manufactured with methods to ensure high quality and to meet the high expectations of our customers. TriMark warrants this product to be free from workmanship defects and will remedy issues per TriMark's warranty policy.

Remote transmitter FOBs, batteries, and other equipment subject to normal wear and deterioration may need to be replaced periodically by dealer and/or end user and are not covered by this warranty. TriMark will not be liable for indirect, special, incidental or consequential damages.

Contact TriMark for specific mounting details, such as drawings, placement suggestions, mounting hardware, etc.

Appendix A: Mounting Information

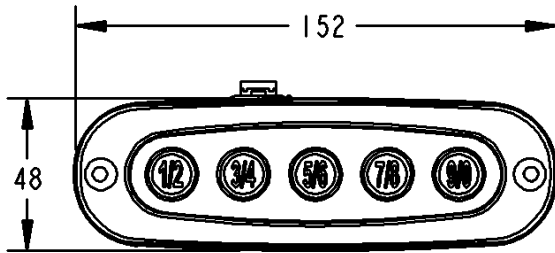

Units in millimeters

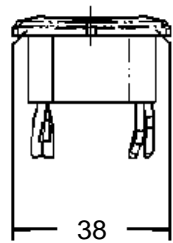
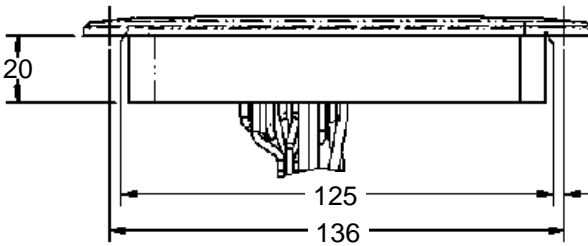

Appendix B: Wiring Information

Wire Identification:

TERMINAL IDENTIFICATION

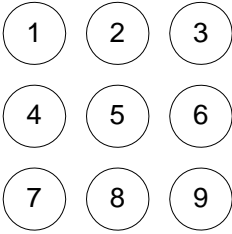

1. Red / White Wire – 12V output (relay coil)
2. White / Green Wire - lock all
3. White / Red Wire – unlock all with 1/2 secure operation (entry doors)
4. Brown Wire—unlock with 3/4 secure operation (bank 1)
6. Purple Wire – Output actuated with 9/0 secure operation (lights)
7. Red Wire - system power, 12-14V
8. Black Wire - system ground
9. Yellow Wire - ground for entering learn mode



Wiring Diagram

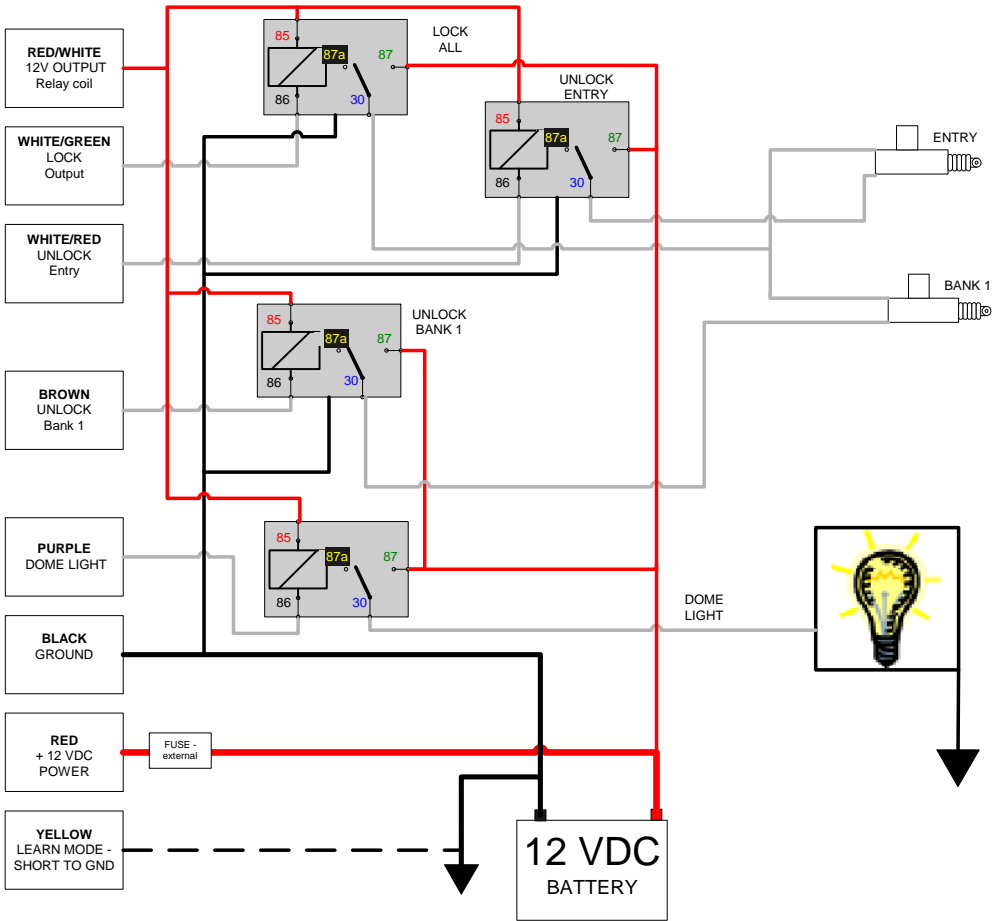

Notes



500 Bailey Avenue
P.O. Box 350
New Hampton, Iowa 50659 U.S.A.
Tel: 641-394-3188
Fax: 641-394-2392
www.trimarkcorp.com

UM10
21067-01
11/10-3